

CARRELLINI PER CATENE IN ACCIAIO STAMPATO

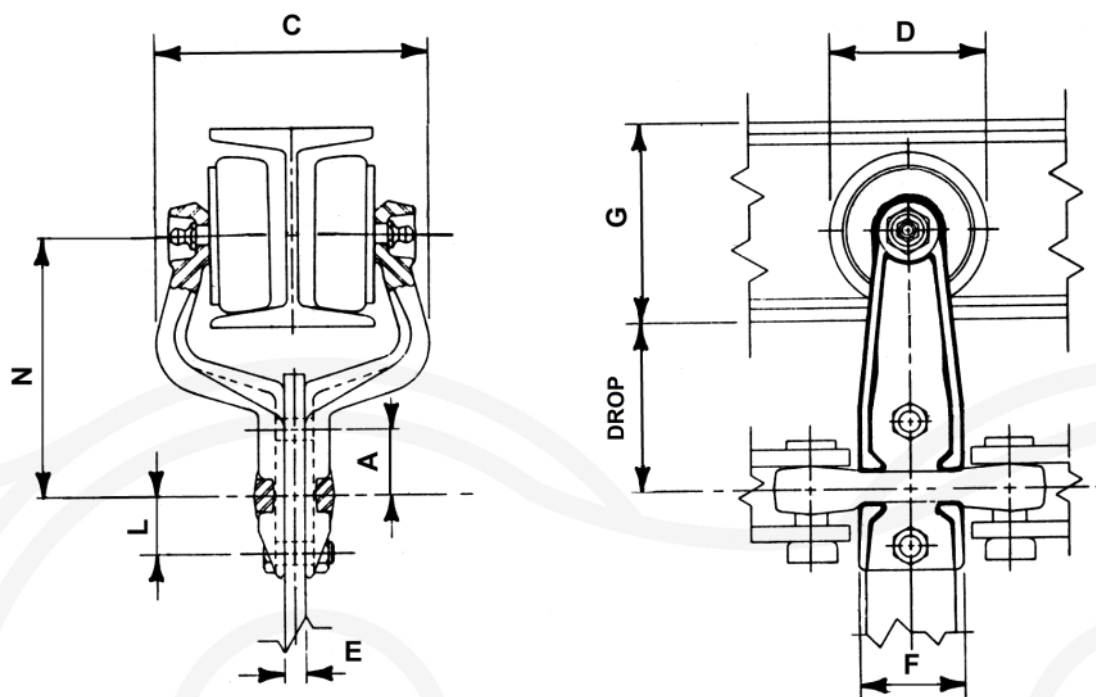

Catene Ing. Negri



N° CATENA	Passo (mm)	DROP (mm)	Ingombro carrello C	Diam. rullo D	Spessore appendino E	Altezza putrella G	Bullone Sup. A	Bullone Inf. L	Rullo N	Largh. Staffa F	Peso Carrello (Kg)	Portata Max. (Kg)
348	76,2	63,5	100,0	59,0	6,0	80	26,0	22,0	100	38,1	1,1	100
						100						
458	102,4	81,0	138	80,0	10,0	120	33,5	20,5	127	44,5	2,5	200
						140						
458 A	102,4	101,6	130	80,0	10,0	120	33,5	20,5	148	44,5	2,6	200
						140						
458 B	102,4	108	130	80,0	10,0	120	45,0	20,0	154	44,5	2,6	200
						140						
458 C	102,4	108	138	100	10,0	120	45,0	20,0	164	44,5	3,3	360
						140						
678	153,2	101,6	175	125,4	12,0	160	41,5	28,5	174	76,2	7,7	550
						180						
678 A	153,2	87,3	142	80,0	12,0	120	31,0	23,0	135	76,2	3,2	200
						140						