

CATENE FLEYER SERIE UF

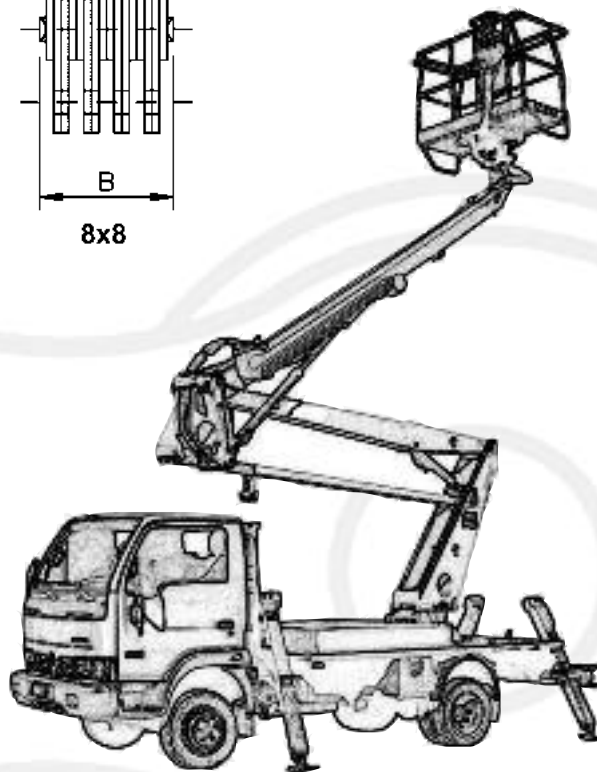

Catene Ing. Negri

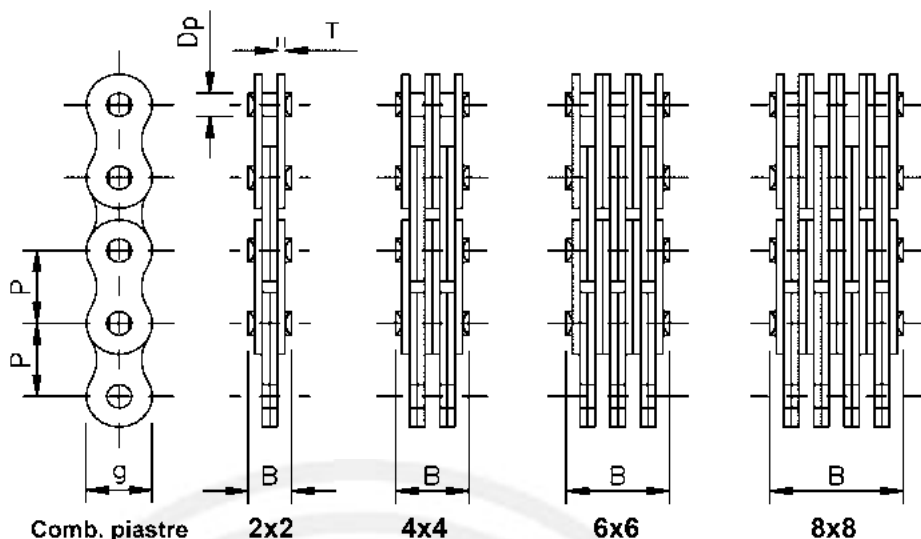

SERIE UF	Passo (mm) P	Comp. piastre	Diametro Perno Dp	Altezza Piastre g	Spessore Piastre T	Lungh. Perno B	Carico di rottura min. (N)	Peso (kg/mt)
UF 922	9,525	2X2	3,58	7,25	1,30	8,00	9.200	0,22
UF 923		2X3		7,25	1,30	9,15	9.200	0,28
UF 944		4X4		7,25	1,30	12,80	18.500	0,42
UF 944R		4X4		7,9	1,57	14,90	–	0,52
UF 966		6X6		7,25	1,30	18,20	27.800	0,62
UF 966R		6X6		7,9	1,57	21,50	–	0,77
UF 988		8X8		7,25	1,30	24,00	37.000	0,82
UF 1222	12,70	2X2	4,45	11,0	1,50	7,90	17.800	0,39
UF 1244		4X4			1,50	14,60	37.600	0,74
UF 1244R		4X4			1,70	16,35	–	0,84
UF 1266		6X6			1,50	19,90	44.500	1,10
UF 1288		8X8			1,50	27,40	77.000	1,47
UF 1522	15,88	2X2	5,08	12,95	1,59	8,90	22.200	0,53
UF 1544		4X4				16,10	44.500	1,00
UF 1566		6X6				22,90	66.700	1,45
UF 1588		8X8				29,50	88.000	2,05